

MD-200 & MD-220 Detector Instructions

Installation

1. Select the lowest practical location for Sensor 1 as close as possible to the potential source of an LP Gas leak. (Typically below/behind the stove)
 2. Select the lowest practical location for Sensor 2 (MD-220) in the bilge, cellar, pit or other source of a potential Gas leak.
- Important: Do not mount sensors where they may be exposed to water, dampness, stood on or physically damaged.
3. Mount the control box in desired location so that it is easily visible/accessible.
 4. Fit Gas Shut Off valve into LP Gas line between the LPG Bottle & Regulator ensuring the flow is correct as indicated on the valve.
 5. Follow wiring diagram to complete installation.

Notes:

Relay 1 Contacts (Max - 24V, 2 Amp. Fuse appropriately)

C (Common) & NC (Normally Closed) contacts closed when power OFF, during Warm Up or ALARM

C (Common) & NO (Normally Open) contacts closed when SAFE

Relay 2 Contacts (Max - 24V, 2 Amp. Fuse appropriately)

C (Common) & NC (Normally Closed) contacts closed when Power Output LED OFF

C (Common) & NO (Normally Open) contacts closed when Power Output LED ON

All Relay 2 contacts open when power OFF, during Warm Up or ALARM

Jump Pin OFF or ON Selection

ON Setting – (Factory Setting) The unit will start up automatically when power is applied (Ideal when using detector on Caravan/Boat with main isolator switch or mains power as it will automatically restart after power failure)

OFF Setting – The unit will not start up automatically when power is applied

EXT ALARM INPUT is optional and will trigger an alarm from an external source (ie. CO-100 Carbon Monoxide Detector). Requires >6V DC to trigger Alarm. See wiring diagram for connections

EXT OUT is optional and used to trigger the negative side of a relay. Contact for further information.

IMPORTANT – DO NOT adjust the variable potentiometers or calibration will be lost!!!

Operation

1. Press “ON-OFF” button to power unit on (one short beep, ON-OFF window green)
2. Allow up to 30 seconds for unit to warm up and reach operation mode (two short beeps) This time varies depending on sensor temperature and other variables
3. After warm up and Sensor(s) SAFE the Blue SAFE LED will be illuminated as well as the “Power Output” (Green LED) for the Solenoid/Relay 2 Contacts active
4. Press the “Power Output” button to toggle the Solenoid/Relay 2 contacts ON/OFF
5. Hold the “TEST” button to force an ALARM, Test relay contacts & Gas flow/Appliances are shutting down.

LIVE SENSOR STATUS (Yellow LED's = Sensor1, Red LED's = Sensor2)

FAULT LED – Sensor is not connected, faulty or cable damaged.

GASES LED – Sensor had detected above 25% LEL Propane or Equivalent

Neither LED on – Sensor is SAFE

Default ALARM Functions as below

MD-200

-Audible Tone & ALARM LED will cycle ON/OFF at 1sec intervals for 1minute

-After 1minute if GAS still detected LED indication will continue as above with Audible Tone every 30seconds (2x 1sec Beeps)

-Once Gas level is safe, the detector will return to SAFE and Power output will return to previous set state before alarm.

MD-220

-Audible Tone & ALARM LED will cycle ON/OFF at 1sec intervals for 1minute

-After 1minute LED indication will continue as above with Audible Tone every 30seconds (2x 1sec Beeps while Gas still detected and 2x short Beeps once gas level is safe)

-Once the Gas Level is SAFE the Power needs to be reset using the ON-OFF button to restore SAFE operation.

Note: ALARM Functions can be altered between models. Contact for further information.

Aust. Compliance, Standards & Regulations

This detector/solenoid conforms with the following Marine, Caravan & Automotive Australian Standards/Regulations:

-AS13425, AS4629, AS5601.2, NSCV PartC-Section5-Subsection5C & ULS Section5-Part9

-This detector also suits & conforms to many other standards/application so please contact if you have a specific standard/regulation you are required to adhere to.

Warranty

Peel Electronics P/L products are designed to provide unlimited service, provided products are not tampered with or damaged in any way. They are warranted for a period of 1 year from purchase date & the Sensors are backed by the manufacturer of the sensor.

In no case shall Peel Electronics P/L Liability under any other remedy prescribed by law exceed the purchase price of the Gas Detector and is not a substitute for property, disability, life or any other insurance coverage, appropriate insurance coverage is the owner's responsibility.

Please Note –

Certain Applications using Peel Gas Detectors may involve potential risks of Death, Personal Injury, or severe property or environmental damage (“Critical Applications”). Peel Gas Detectors are not Authorized, or warranted to be suitable for use in Life-Support Devices or systems or other Critical Applications. Inclusion of Peel Gas Detectors is understood to be fully at the Customer's Risk.

Detectors are calibrated under set conditions and where applicable for replace-ability of sensors, average 'batch' calibration is performed. Therefore in 'field' bump test results may vary from sensor to sensor.

Peel Electronics recommends a 12 monthly calibration and 6 monthly bump test on all gas detectors. Important: this frequency may differ in some applications, or for compliance to certain Australian Standards and Regulatory Requirements. Eg. AS5034 requires 6monthly calibration to CO2/O2 Detectors.

MD-200 & MD-220 Peel LPG/Propane Detector 12V DC Wiring Example to Activate Solenoid

Approx Current Draw

MD-200 Detector: 12V DC – 130ma, 24V DC – 65ma
 MD-220 Detector: 12V DC – 220ma, 24V DC – 100ma
 12V Solenoid: 600ma

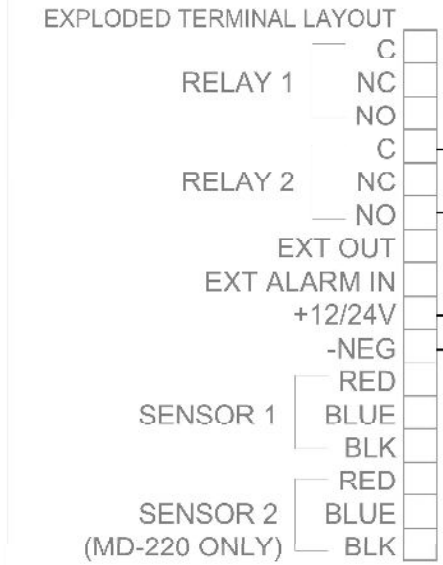
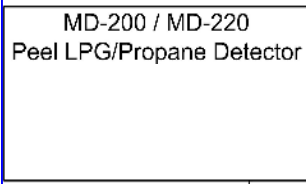

SIMPLIFIED POWER CONNECTIONS FOR ABOVE WIRING DIAGRAM

Solenoid & link can be wired through Relay 1 Contacts, however the Power Output button will not Control the Solenoid

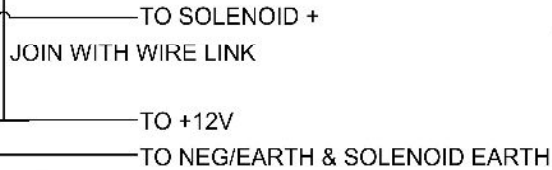

Note: This unit is suitable for 12V DC, 12V AC, 24V DC & 24V AC
 The SOLENOID SUPPLIED is 12VDC ONLY, use a Voltage reducer if using 24VDC source (Jaycar MP-3350)
 For AC connection fit one wire into +12/24V Terminal & the other into -NEG Terminal. (Fuse 1 wire accordingly)
 Wire Relays according to requirements – MAX 24V 2A LOAD
MD-220 Operation Note:
 In the event of an ALARM/TEST, once area is vented reset the LPG/Propane Detector to clear alarm and activate solenoid again

See below Note

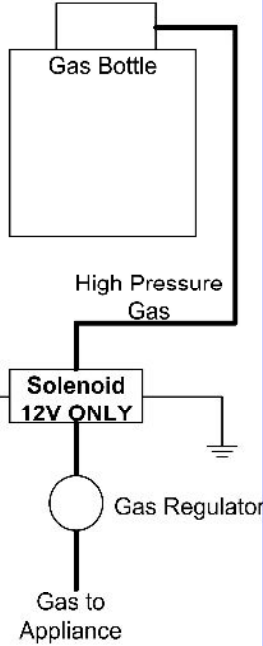

CO-100 Wiring to Activate Solenoid when used with MD-200 Series Peel LPG/Propane Detector

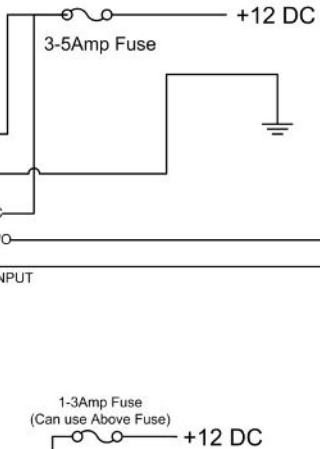
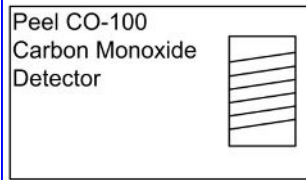
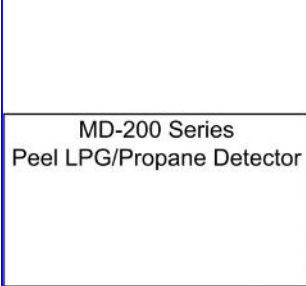

Operation Note:
 In the event of an ALARM/TEST, once area is vented reset the LPG/Propane Detector to clear alarm and activate solenoid again

